



Kit Contents		
Description	Part No	Pcs
Shock absorber		2
Dust boot	10216-01	2
Top mount	25633-39	2
Lock nut	24636-03	4
Lower spring seat	24635-03	2
Spring	47010-31	2
Self lock nut M12	24627-02	2
<b>Mounted on shock absorber</b>		
Adjuster	24631-02	2
<b>Used for both front and rear</b>		
C-spanner		1
C-spanner		1
Öhlins sticker		1
Öhlins Owner's Manual		1

**👁 Note!**

Please note that there can be small differences between your product and the images in these instructions.

**👁 Note!**

Please note that during storage and transport, especially at high ambient temperature, some of the oil and grease used for assembly may leak and stain the packaging. This will not cause damage to the product, wipe off the excessive oil or grease with a cloth.

**👁 Note!**

Before you install this product, check the kit contents. If anything is missing, please contact an Öhlins dealer.

**⚠ Warning!**

Before you install this product, read the Öhlins Owner's manual. This product is an important part of the vehicle and the vehicle stability.

## Shock Absorber Kit for Lexus IS250 (GSE20) and IS350 (GSE21)

# LES M100S1 FRONT

## Mounting Instructions



# MOUNTING INSTRUCTIONS

## **⚠ Warning!**

We strongly recommend to let an Öhlins dealer install this product.

## **⚠ Warning!**

If you work with a lifted vehicle, make sure that it is safely supported to prevent it from tipping over.

## **👁 Note!**

When you work with this product, see the vehicle service manual for vehicle specific procedures and important data.

## **👁 Note!**

Before you install this product clean the vehicle.

**1**

Raise the vehicle and put it on jack stands.

## **⚠ Warning!**

Ensure that it is securely supported.

**2**

Remove the front wheels.

**3**

Remove the lower and the upper attachments and remove the original shock absorbers.

## **👁 Note!**

When removing the original shock absorbers, the headlight level sensor must be removed.

**4**

Tighten the lower spring seat and the lock nut to 50 - 60 Nm.

Fit the dust boot, the spring, the rubber seat, the top mount and the adjuster according to fig 1. Tighten the self lock nut to 30 Nm.

## **👁 Note!**

When tightening the top mount nut, the shock absorber shaft must be held in position with a flat screwdriver.

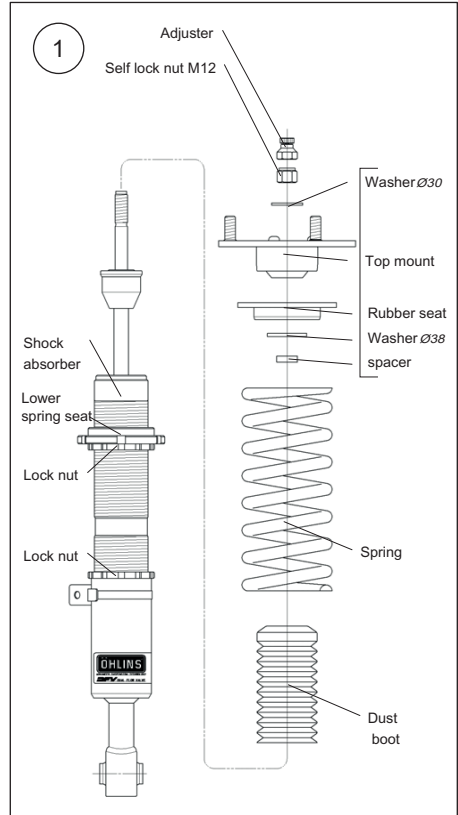

# MOUNTING INSTRUCTIONS

**5**

Install the Öhlins shock absorbers on the vehicle.

**6**

Fasten the upper attachments.

**👁 Note!**

---

*Make sure that all bolts are tightened to the correct torque and that nothing fouls or restricts movement of the shock absorber when it is being fully compressed or extended.*

---

**7**

Make sure that all removed parts are reinstalled in the same way as they were before the installation of the Öhlins shock absorber.

# ADJUSTMENTS

## **⚠ Warning!**

*Before you ride/drive, always make sure that the setup is according to the recommended setup data. Read about adjustments and setting up in the Öhlins Owner's Manual before you make any adjustments. Contact an Öhlins dealer if you have any questions about setting up.*

The standard preload is 2 mm from a free length of 200 mm, giving 198 mm installed length, see fig 3.

# SETUP DATA

## Recommended set-up

Rebound	10	clicks
Spring preload	2	mm
Shock absorber length	542	mm

## Spring

Spec ..... H200, ID65, 100 N/mm

## The actual vehicle height

With both the preload and height adjustments in their standard positions, the vehicle is lowered approximately 20 mm when compared to the original suspension. As the height adjuster is turned one rotation, the position moves 1.5 mm.

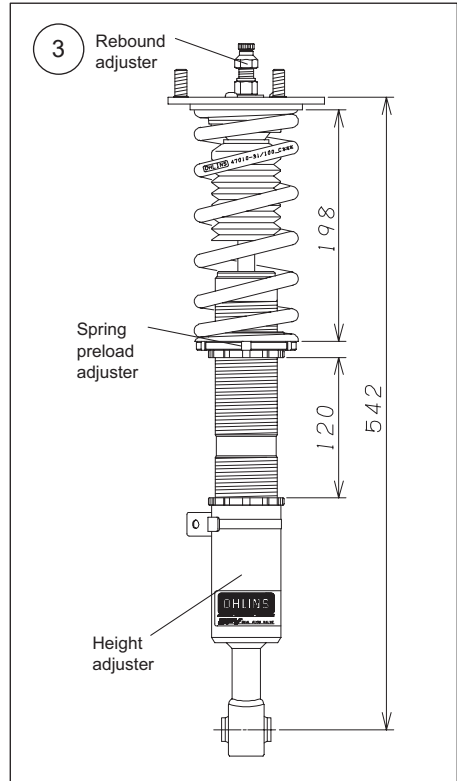

## **⚠ Warning!**

*The adjustment range is the standard position  $\pm 15$  mm. If the bracket is moved outside the adjustment range, it may come loose.*

Öhlins products are subject to continuous improvement and development, therefore, although these instructions include the most up-to-date information available at the time of printing, minor updates may occur.

To find the latest information contact an Öhlins distributor. Please contact Öhlins if you have any questions regarding the contents in this document.

Part no. MI\_LESMI00S1\_0  
Issued 2023-02-24

© Öhlins Racing AB. All rights reserved. Any reprinting or unauthorized use without the written permission of Öhlins Racing AB is prohibited.

Öhlins Racing AB  
Box 722  
S-19 27 Upplands Väsby, Sweden  
Phone +46 8 590 025 00  
fax +46 8 590 025 80



[www.ohlins.com](http://www.ohlins.com)



Kit Contents		
Description	Part No	Pcs
Shock absorber		2
Self lock nut M12	24618-04	2
Lock nut	24636-03	4
Spring	47060-15	2
Bushing spacer	24629-12	4
Spacer	24629-09	2
Lower spring seat	24635-04	2
Lock nut	24636-04	2
<b>Mounted on shock absorber</b>		
Adjuster	24631-05	2
<b>Used for both front and rear</b>		
C-spanner		1
C-spanner		1
Öhlins sticker		1
Öhlins Owner's Manual		1

**👁 Note!**

Please note that there can be small differences between your product and the images in these instructions.

**👁 Note!**

Please note that during storage and transport, especially at high ambient temperature, some of the oil and grease used for assembly may leak and stain the packaging. This will not cause damage to the product, wipe off the excessive oil or grease with a cloth.

**👁 Note!**

Before you install this product, check the kit contents. If anything is missing, please contact an Öhlins dealer.

**⚠ Warning!**

Before you install this product, read the Öhlins Owner's manual. This product is an important part of the vehicle and the vehicle stability.

## Shock Absorber Kit for Lexus IS250 (GSE20) and IS350 (GSE21)

# **LES M100S1 REAR**

### Mounting Instructions



# MOUNTING INSTRUCTIONS

**1**  
Raise the vehicle and put it on jack stands.

**⚠ Warning!**  
*Ensure that it is securely supported.*

**2**  
Remove the rear wheels.

**3**  
Remove the lower and the upper attachments and remove the original shock absorbers.

**4**  
Tighten the lower spring seat and the lock nut to 50 - 60 Nm.  
Fit the bushing spacers, the spring, the top mount and the adjuster according to fig 1.  
Tighten the self lock nut to 30 Nm.

**👁 Note!**  
*When tightening the top mount nut, the shock absorber shaft must be held in position with a flat screwdriver.*

**5**  
Install the Öhlins shock absorbers on the vehicle.

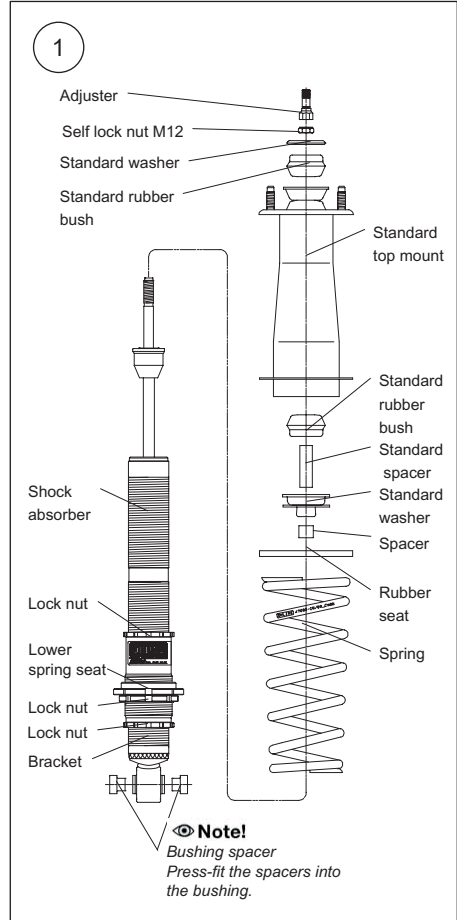

# MOUNTING INSTRUCTIONS

6

Make a  $\varnothing 15$  hole in the side panel according to fig 2, and pass the adjuster.

**Note!**

*Make sure that all bolts are tightened to the correct torque and that nothing fouls or restricts movement of the shock absorber when it is being fully compressed or extended.*

7

Make sure that all removed parts are reinstalled in the same way as they were before the installation of the Öhlins shock absorber.

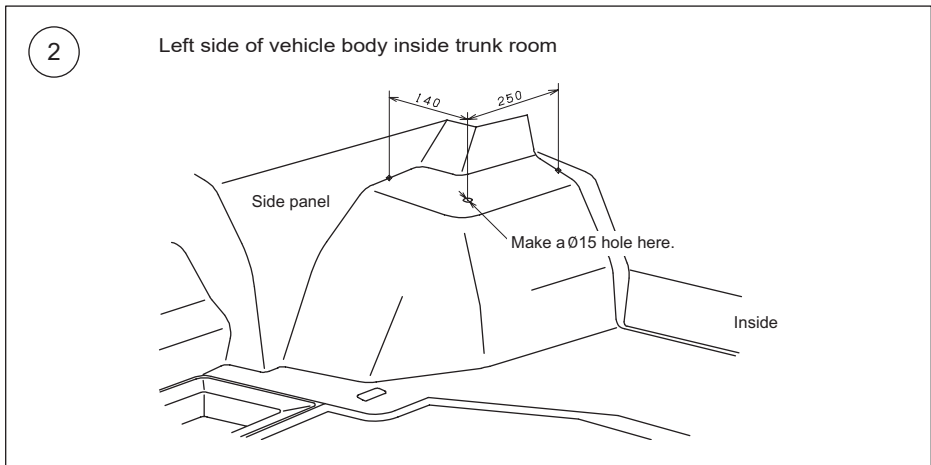

# ADJUSTMENTS

## ⚠ Warning!

Before you ride/drive, always make sure that the setup is according to the recommended setup data. Read about adjustments and setting up in the Öhlins Owner's Manual before you make any adjustments. Contact an Öhlins dealer if you have any questions about setting up.

The standard preload is 2 mm from a free length of 250 mm, giving 248 mm installed length, see fig 2.

# SETUP DATA

## Recommended set-up

Rebound	10	clicks
Spring preload	2	mm
Shock absorber length	590	mm

## Spring

Spec .....H250, ID70-90, 60N/mm

## The actual vehicle height

With both the preload and height adjustments in their standard positions, the vehicle is lowered approximately 20 mm when compared to the original suspension. As the height adjuster is turned one rotation, the position moves 1.5 mm.

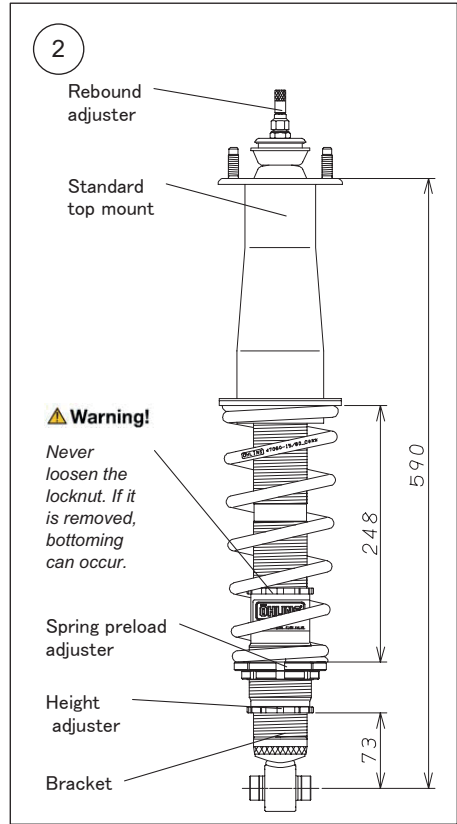

## ⚠ Warning!

The adjustment range is the standard position  $\pm 15$  mm. If the bracket is moved outside the adjustment range, it may come loose.

Öhlins products are subject to continuous improvement and development, therefore, although these instructions include the most up-to-date information available at the time of printing, minor updates may occur.

To find the latest information contact an Öhlins distributor. Please contact Öhlins if you have any questions regarding the contents in this document.

Part no. MI\_LESMI00S1\_0  
Issued 2023-02-24

© Öhlins Racing AB. All rights reserved. Any reprinting or unauthorized use without the written permission of Öhlins Racing AB is prohibited.

Öhlins Racing AB  
Box 722  
S-194 27 Upplands Väsby, Sweden  
Phone +46 8 590 025 00  
fax +46 8 590 025 80



[www.ohlins.com](http://www.ohlins.com)