

Kit Contents		
Description	Part No	Pcs
Screw M6x16	00432-07	2
Screw M6x16	05404-13	1
Bracket	01165-24	1
Bracket reservoir	03102-24	1
C-spanner single	00710-02	1
Sticker set Öhlins		1
Owners manual road & track	07241-02	1

👁 Note!

Please note that there can be small differences between your product and the images in these instructions.

👁 Note!

Please note that during storage and transport, especially at high ambient temperature, some of the oil and grease used for assembly may leak and stain the packaging. This will not cause damage to the product, wipe off the excessive oil or grease with a cloth.

👁 Note!

Before you install this product, check the kit contents. If anything is missing, please contact an Öhlins dealer.

⚠ Warning!

Before you install this product, read the Öhlins Owner's manual. This product is an important part of the vehicle and the vehicle stability.

Shock absorber for Aprilia RS 660/Touno 660

AP 660

Mounting Instructions

MOUNTING INSTRUCTIONS

⚠ Warning!

We strongly recommend to let an Öhlins dealer install this product.

⚠ Warning!

If you work with a lifted vehicle, make sure that it is safely supported to prevent it from tipping over.

👁 Note!

When you work with this product, see the vehicle service manual for vehicle specific procedures and important data.

👁 Note!

Before you install this product clean the vehicle.

1

Put the motorcycle on a work stand so that the rear wheel barely touches the ground.

2

Remove the shock absorber following the Aprilia work shop manual. Remove the rear sub frame side covers to access the upper shock mounting and to fit the reservoir bracket.

3

Place the steel bracket part 01165-24 over the rear sub frame tube just behind the brake fluid reservoir.

4

Mount the reservoir bracket to the steel bracket part with the hex head screws 00432-07 start with the upper [1] and then the lower [2], do not tighten them completely yet.

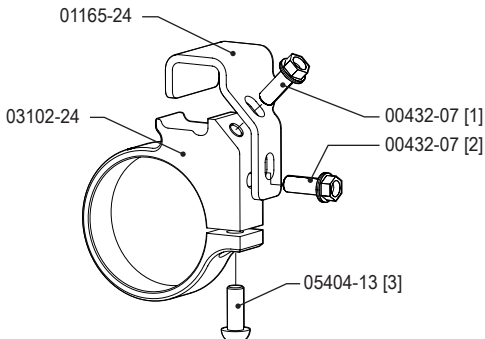

5

Slide the bracket assembly forward as much as possible to make it easier to fit the reservoir into the clamp.

6

Install the Öhlins shock absorber with the reservoir to the right side of the bike. Fit the frame bracket screw first and then the swing arm bracket screw.

👁 Note!

Lower the vehicle so that the suspension is slightly compressed before you tighten the screws.

7

Fit the reservoir into the bracket assy according to the picture.

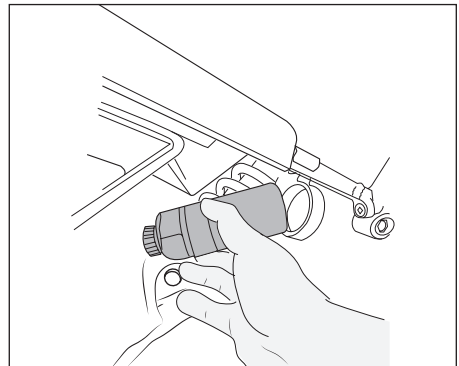
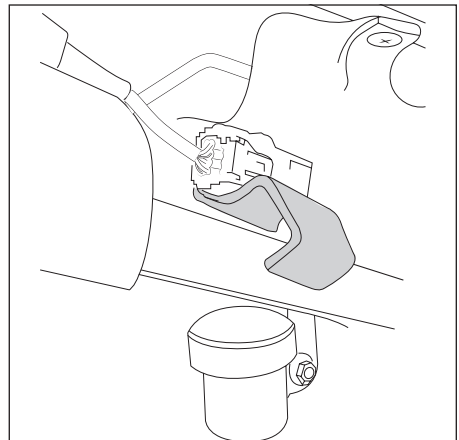

MOUNTING INSTRUCTIONS

8

Tighten the Bracket screws [1] and [2] and leave 10 mm between the mounting point for the side fairing (just behind the brake fluid reservoir) and the reservoir bracket assy.

9

Position the reservoir so that the hose is routed nicely and have no clearance issues when the rear suspension is moving. Tighten the reservoir clamp screw [3].

10

Re-mount the remaining parts according to the Aprilia work shop manual.

⚠ Caution!

Make sure that you tighten all screws to the correct torque and that nothing fouls or restricts movement of the shock absorber/front fork/steering damper when the suspension is fully compressed or extended.

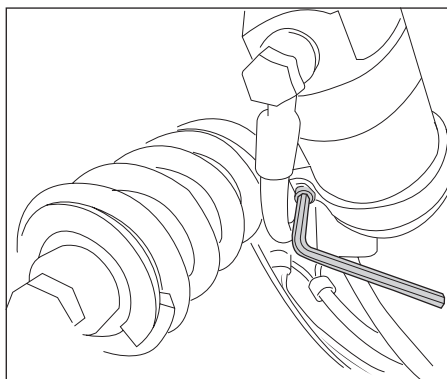
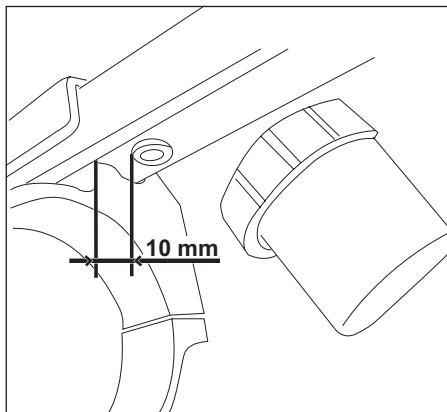

ADJUSTMENTS

⚠ Warning!

Before you ride/drive, always make sure that the setup is according to the recommended setup data. Read about adjustments and setting up in the Öhlins Owner's Manual before you make any adjustments. Contact an Öhlins dealer if you have any questions about setting up.

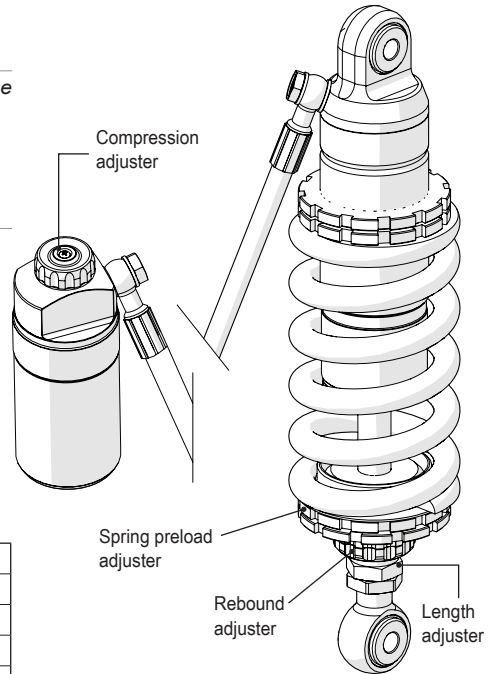

SETUP DATA

Length	309	mm
Stroke	51	mm
Compression	10	clicks
Rebound	20	clicks
Spring preload	7	mm
Spring	01093-64	
Spring rate	160	N/mm
Spring free length	150	mm

Alternative springs

Rider weight [kg]	50	60	70	80	90	100	110
Spring rate [N/mm]	140	140	160	160	160	180	180
Preload [mm]	6	7	6	7	8	7	8
Part number	01093-54	01093-54	01093-64	01093-64	01093-64	01093-74	01093-74

Öhlins products are subject to continuous improvement and development, therefore, although these instructions include the most up-to-date information available at the time of printing, minor updates may occur.

To find the latest information contact an Öhlins distributor. Please contact Öhlins if you have any questions regarding the contents in this document.

Part no. MI_AP 660_1
Issued 2022-06-07

© Öhlins Racing AB. All rights reserved. Any reprinting or unauthorized use without the written permission of Öhlins Racing AB is prohibited.

Öhlins Racing AB
Box 722
S-194 27 Upplands Väsby, Sweden
Phone +46 8 590 025 00
fax +46 8 590 025 80



www.ohlins.com